



[www.insize.com](http://www.insize.com)



## **OPERATION MANUAL**

**Model ISP-Z3015B  
Erect Image Profile Projector**



## 1. Instrument usage

ISP-Z3015B digital measuring projector is a precise and excellent effective measuring instrument integrating optic, mechanic and electricity. Used widely in the trade of mechanic, meter, electronics and light industry, as well as the laboratories, metric room and workshop of the academes, research institutions, measurement-inspecting department etc. This instrument can sufficiently inspect various kinds of surface and outline of complicated work-piece. Such as template, cam, tread and gear, perform milling cutter including machine tools and parts.

## 2. Instrument specification

### 2.1 Projective screen

- 2.1.1 Screen size(mm): $\Phi 312$ , used range $>\Phi 300$
- 2.1.2 Screen rotary range:0~360°
- 2.1.3 Resolution:1'or 0.01°, Rotating accuracy: 6'

### 2.2 Lens

(Size unit: mm)

Magnification	10X(standard)	20X(optional)	50X(optional)	100X(optional)
Object view	$\Phi 30$	$\Phi 15$	$\Phi 6$	$\Phi 3$
Working distance L	75m	69	26	26

### 2.3 Table And Dimensions:

(Size unit: mm)

Model	ISP-Z3015B
X axis travel	150
Y axis travel	100
Metal table size	340×152
Glass table size	196×96
Resolution	0.001
Z axis travel	100

### 2.4 Illumination

- 2.4.1 The illumination of transmission and reflection are 24V、150W-halogen lamp.

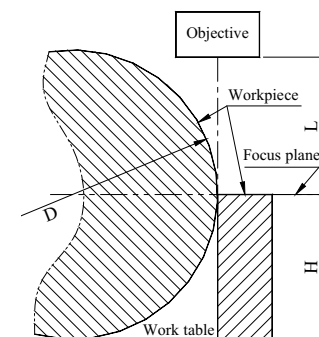

Fig. 1

## 3. Instrument working principle

The working principle of projector is shown in Fig.2. Put a work-piece Y on the table. The objective O forms and magnifies the image Y' of the work-piece Y on the projection screen P. User not only can measures Y' directly with a common glass scale, but also can compare with standard picture on the projection screen. Moving the table, the measuring result can be shown on the digital indicator. In Fig.2, S1 is transmission illumination source, S2 is reflection illumination source; K1 is transmission condenser, K2 is reflection condenser. These two groups of sources can be used respectively, and also can be used together. The semi-transmitted mirror L is only used in the reflection illumination.

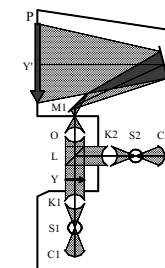

Fig. 2 working principle

#### 4. Construction and function

The structure of the instrument is shown in Fig.3. It is mainly consisted of projection case, shell and table and so on. The optical system of the instrument including objective, mirror and projection screen are all in the projection case. The digital indicative screen is located in the right external of projection case. The illumination system, electrical control system, digital display device and cool device are all in the main shell of the instrument. The table can be moved in X, Y and Z directions. It is provided with grating sensor, and we can make high precision measurement. The projection screen can be rotated in 360° directions and we can get angle count by an angle coder. A "line is made on the projection screen. It is a base reference for measuring length and angle.

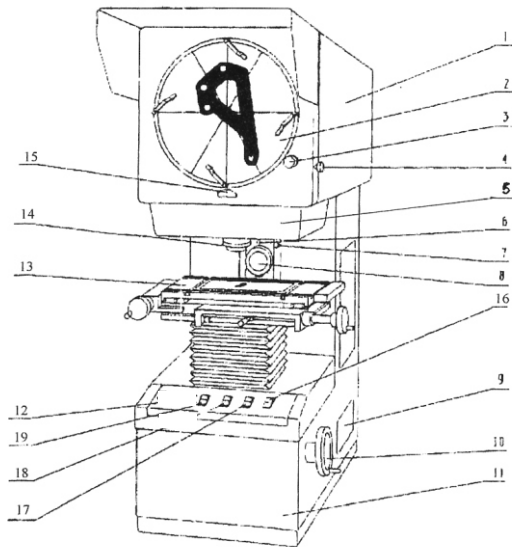

Fig. 3 The structure of the instrument

- |                                      |  |
|--------------------------------------|--|
| 1. Projection case                   | 11. Shell                                    |
| 2. Projection screen                 | 12. Control panel                            |
| 3. Rotation wheel                    | 13. Worktable                                |
| 4. Lock wheel                        | 14. Objective                                |
| 6. Up and down handle for reflection | 15. Zero indicator                           |
| 7. Lock screw                        | 16. Reflection illumination switch           |
| 8. Reflection condenser              | 17. Zoom switch of transmission illumination |
| 9. Power socket board                | 18. Switch of transmission illumination      |
| 10. Up and down handle of worktable  | 19. Power switch                             |

#### 5. Electrical principle

Electrical principle (just for illumination and control) is shown in Fig. 4. The illumination system has two parts. One is transmission illumination and another is reflection illumination. They have a common power transformer, reflection illumination adopts 24V 150W tungsten halogen lamp, and transmission illumination adopts 12V 100W tungsten halogen lamp, and cool by an axial-flow fan.

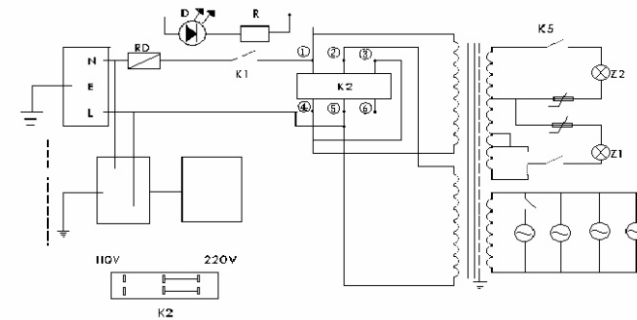

Fig. 4 Electrical principle

#### 6. Application and operation

##### 6.1. Operation of digital displaying part

The operation of digital displaying part is displayed in the "Operation manual for display device".

## 6.2. Moving the worktable and measurement

Moving the worktable in X or Y direction, the moving value is displayed on the indicator. It is available to focus the table roughly when turning handwheel 10.

## 6.3. Rotating projection screen

Loosen 4 and turn 3; it is available to rotate the projection screen 2 in 360° directions clockwise or anticlockwise. Angle value is displayed on the indicator.

## 6.4. Adjustment of illuminating lamp

This step is taken during the process of replacing the lamp and checking the instrument.

When adjusting the contour illumination lamp, take away objective and open the front door in the right, loose the lock screw on the lampstand and adjust the lamp in the front, back, left and right to filament imagery on the center of projection screen clearly, then lock the lock screw on the lampstand .

When adjusting the surface illumination lamp, cover the objective with relevant semi-transparent and semi-transmitted mirror. Place the work-piece on the worktable, and loose 7. Open the back door in the right, and loose the lock screw on the lampstand. Then adjust the lamp in front, back, left and right. At the same time, move reflection condenser 8 up and down with reflection condenser until to the imagery of work-piece surface on the center of projection screen clearly, then lock 7 and the lock screw on the lampstand .

## 6.4. Replacement of objective

Select different objective according to your need. Objective is connected with the projection case through thread.

## 7. Measuring method

Before measurement, check the correct positions of different parts on the instrument and clean the work-piece.

## 7.1 Comparing measurement with “standard drawing”

Compare the standard magnified drawing with image of workpiece, the difference is the error of workpiece. The method is common, which can do synthesis measurements of many parameters of workpiece in one time rapidly and precisely. Its step is as following:

- a. Choose the objective with proper magnifications according to the size and form of the work-piece. Make a "standard drawing" according to the chosen magnification. Then put the "standard drawing" onto the projection screen and fix it with elastic pressers.
- b. Place the work-piece in the center of the worktable and raise or lower the worktable until a sharp image is formed on the projection screen.
- c. Move the worktable and turn the projection screen, or move the "standard drawing". Just bring the image on the projection screen in coincident with the "standard drawing". The deviation concerned can be measured directly with the glass ruler. The deviation can also be directly read out on digital display by the longitudinal and transverse reading devices of worktable. In addition to, you can drawing the maximum and minimum limit tolerance zone on the "standard drawing", so that can know the workpiece whether is qualified.

## 7.2 Measurement with the help of X or Y grating reading system of the worktable

At the first, bring the measuring size of the work-piece parallel to the moving direction of the worktable. Just move the worktable to bring the image of the work-piece in coincident with the “standard drawing” at one side, zero X or Y. Then move the worktable to bring the image of the work-piece in coincident with the “standard drawing” at the other side. Now the X or Y value is the actual value of measured length.

## 7.3 Directly measuring the magnified image of the work-piece on the projection screen by means of the glass scale.

Such kind of measurement is rather simple and convenient, but it is only suited for measuring certain parts of the work-piece. The quotient of the reading value, obtained on the screen by means of glass scale, divided by the magnification

of the objective is the actual size of the work-piece

#### 7.4 Measuring an angle by means of rotating the projection screen

At first loosen wheel 4, rotating the projection screen 2 to bring the indicative line on it in coincident with the indicative line on the zero indicator 15. At this time, the cross line of the projection screen is parallel to X (Y) coordinate of the worktable. Put a work-piece onto proper position of the worktable. Then rotating the projection screen, aim one of the cross lines on the screen at the contour circumference of the work-piece on both sides. The difference of the two reading is the angle value of the work-piece. There are indicative lines of 30°, 60° and 90° on the projection screen, and these angles can be compared measurement directly .

## 8. Maintenance

The projector is a kind of precision optical instrument. Attention should be paid to its maintenance so as to guarantee the precision and lengthen life of the instrument. The instrument should be installed in a clean room, the temperature of which should be maintained at  $20^{\circ} \pm 5^{\circ}\text{C}$ . The relative humidity of the room should not exceed 60% so as to prevent the optical parts and reflecting mirror from molding and to keep the high quality of the image.

The surfaces of optical parts should be kept clean. They should not be touched with hands. If any dirt, oil fleck or dust are found on the surfaces, they should be removed with soft brushes, or they should be removed with clean linen or lens paper soaked in methyl benzol or in a mixture of alcohol and ether. Try to rub the optical surfaces as less as possible.

The instrument should not be operated with a big force. All bare metal surfaces of the instrument and the accessories should be wiped clean and coated with protection grease after operation.

When work-piece with larger diameter is to be measured, take down objectives 50x and 100x and place them into the accessory box.

Objectives, guides and condenser have higher precision. They should not be dismantled optionally. If it is necessary, they should be sent to the specialized factories for repair.

## 9. Unpacking and installation

Take away the cover and the front and back boards of the case. Dismantle the holding clamps and the left and right boards. After this, transfer the instrument to the place where it is to be installed. Then installing and adjusting the four base feet make the installing face of worktable in level.

Projection screen should not face the window and any strong light source so as not to affect the

contrast of the screen. After the instrument has been placed properly, take away the protection paper carefully. Wipe out the protection grease on the instrument with cloth soaked in aviation gasoline. After the grease is wiped out, some lubricant oil should be applied. For the worktable, take out 6 screws, which fix the worktable and take away the connected plate. At this time, the worktable can move. Take down the red fixing screw under the reflecting sliding board. At last, connect power and the instrument can be used.

**NOTICE:** Voltage of the instrument is set as 220V before leaving the factory. Alternating current 110V is option. If your power is 110V of alternating current, please set power change switch K2 as 110V, at the same time set the digital indicator's power as 110V, and then the instrument can be used.